

Electric Pallet Stacker

Model:

T-CTD10R-E

T-CTD12R-E

T-CTD15R-E

Straddle legs
&
Adjustable forks

The super light Electric Walkie.
Stacker with small turning radius
which is widely used in small
warehouse and super market.

Suit for low level stacking and
short distance transportation.

Super Compact

CE Conforms to
EN ISO3691-1
EN1175-1
EN16307-1



RUZI Tiller Head

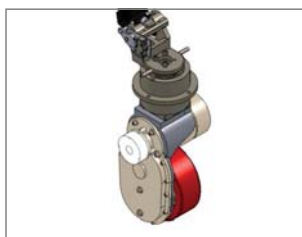

Floor type drive wheel

Model		T-CTD10R-E	T-CTD12R-E	T-CTD15R-E
Load capacity	Q (lbs)	2200	2640	3300
Load centre distance	C (inch)	23.6	23.6	23.6
Load distance, centre of drive axle to fork	X (inch)	30.3	30.3	30.3
Height (lowered)	h13 (inch)	3.1	3.1	3.1
Tyre size (front)		Ø7.6 x 2.7	Ø7.6 x 2.7	Ø7.6 x 2.7
Tyre size (rear)		Ø3.8 x 3.2	Ø3.8 x 3.2	Ø3.8 x 3.2
Additional wheels (dimensions)		Ø5.9 x 2.3	Ø5.9 x 2.3	Ø5.9 x 2.3
Wheels, number front rear (x = driven wheels)		1x + 1/4	1x + 1/4	1x + 1/4
Height, mast lowered	h1 (inch)	84.4 / 74.6 / 84.4	84.4 / 74.6 / 84.4	84.4 / 74.6 / 84.4
Max. lift height	h3 (inch)	63 / 98 / 118	63 / 98 / 118	63 / 98 / 118
Height, mast extended	h4 (inch)	84.4 / 122 / 141.7	84.4 / 122 / 141.7	84.4 / 122 / 141.7
Height of tiller in drive position min./max.	h14 (inch)	26.3 / 51.1	26.3 / 51.1	26.3 / 51.1
Overall length	L1 (inch)	59	59	59
Length to face of forks	L2 (inch)	25.9	25.9	25.9
Overall width	b1 (inch)	31.4	31.4	31.4
Fork dimensions	inch	1.3 x 3.9 x 42.1 (45.2)	1.3 x 3.9 x 42.1 (45.2)	1.3 x 3.9 x 42.1 (45.2)
Width overall forks	b5 (inch)	7.8 ~ 31.4	7.8 ~ 31.4	7.8 ~ 31.4
Ground clearance, centre of wheelbase	m2 (inch)	1.3	1.3	1.3
Aisle width for pallets 39.4"x47.2" crossways	Ast (inch)	89.7	89.7	89.7
Aisle width for pallets 31.5"x47.2" lengthways	Ast (inch)	89.7	89.7	89.7
Turning radius	Wa (inch)	58.6	58.6	58.6
Travel speed (laden / unladen)	mph	2.8 / 3.1	2.8 / 3.1	2.8 / 3.1
Lift speed (laden / unladen)	mph	0.2 / 0.31	0.2 / 0.31	0.18 / 0.24
Lowering speed (laden / unladen)	mph	0.26 / 0.22	0.26 / 0.22	0.26 / 0.22
Battery voltage, nominal capacity K20	V/Ah	24 / 105	24 / 105	24 / 125
Battery weight	lbs	115	115	154
Battery dimensions (L x W x H)	inch	10.2 x 6.6 x 8.5	10.2 x 6.6 x 8.5	13 x 6.7 x 8.5
Service weight (with battery)	lbs	1080 / 1223 / 1267	1080 / 1223 / 1267	1278 / 1422 / 1466

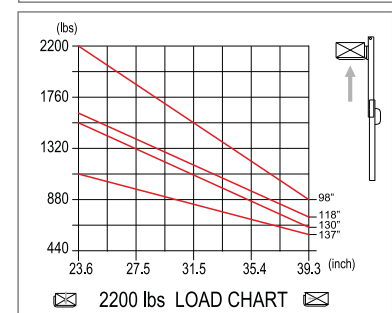
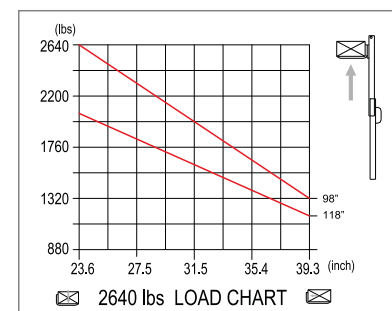
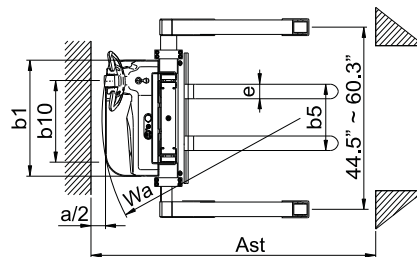
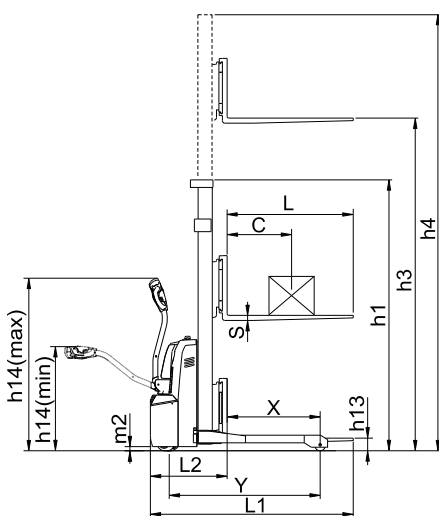

TAILIFT MATERIAL HANDLING TAIWAN CO., LTD.

No. 5, Zili 1st Road, Nankang Industrial Zone, Nantou city 540, TAIWAN
 Tel: +886-49-2263800 Fax: +886-49- 2252919
 Website: www.tailift.com E-mail: insales@tailift.com.tw

TAILIFT MATERIAL HANDLING USA, Inc.

5550 Jurupa St, Ontario, CA 91761
 TEL: (909) 930-9801, (909) 930-9802 FAX: (909) 930-9739
 Website: www.tailift-usa.com

